

THIS DRAWING IS UNPUBLISHED. RELEASED FOR PUBLICATION, 19 .  
 © COPYRIGHT 19 BY AMP INCORPORATED. ALL INTERNATIONAL RIGHTS RESERVED.

LOC AF	DIST 50	P	F	REVISIONS			DATE	APPD
				ZONE	LTR	DESCRIPTION		
					A	REL PER 061A-0171-99	17MAY99	JR/DD

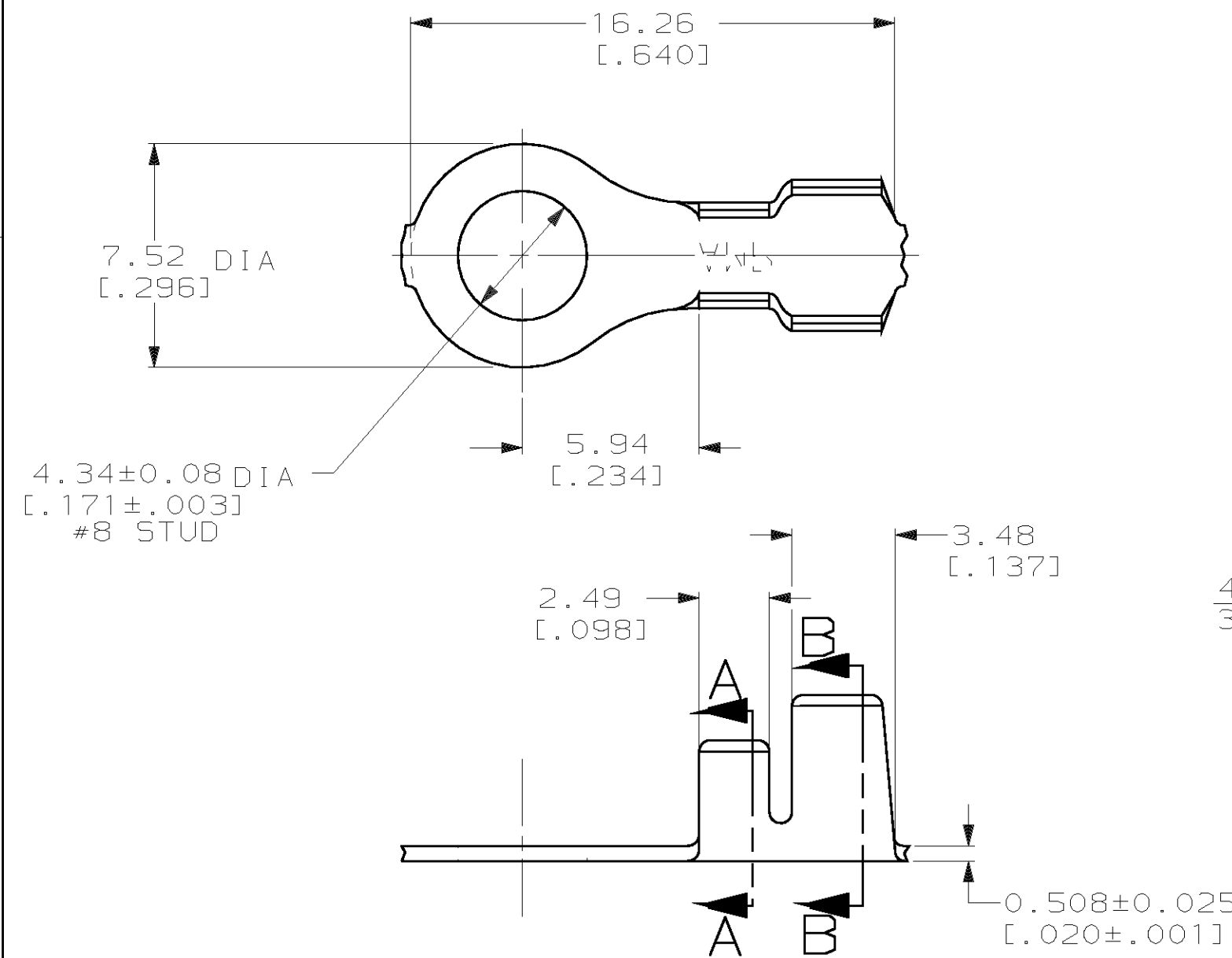

- 1 CONTINUOUS STRIP ON REEL.
- 2 0.003032 [0.000080] MIN TIN PLATE.

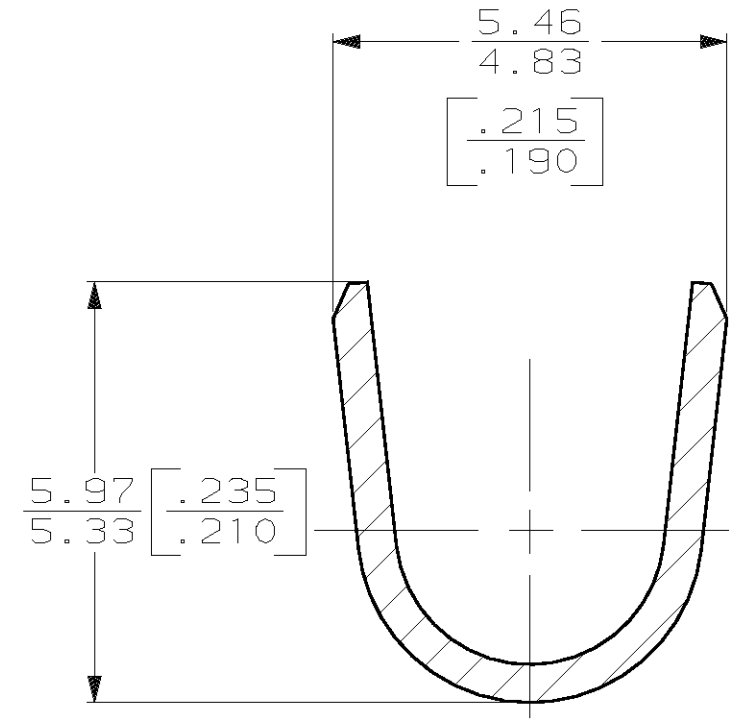
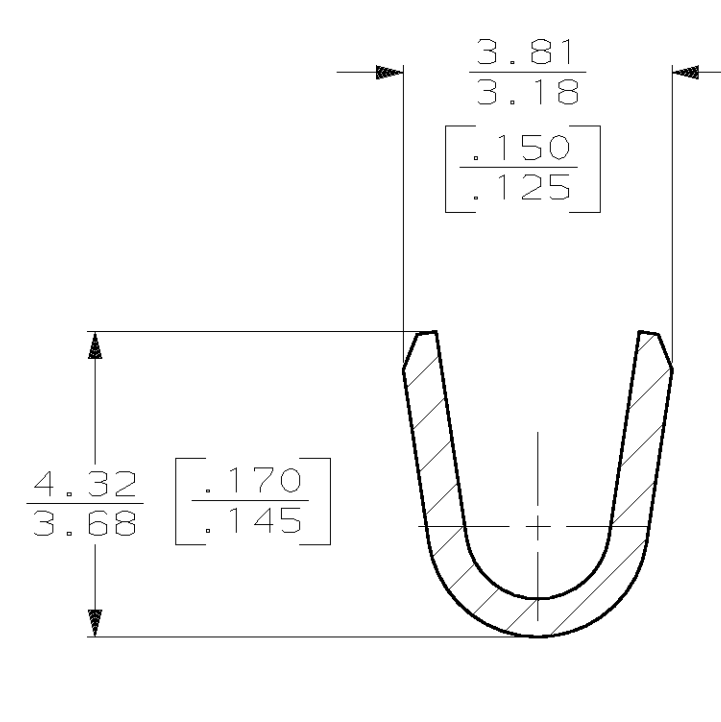

F OR 0	4.57 [0.180]	4.06 [0.160]	F	3.05 [0.120]	2.03 [0.080] [14]	
					1.83 [0.072] [16]	
					1.70 [0.067] [18]	
TYPE	WIDTH	STRIP LENGTH ±0.38 [±0.015]	TYPE	WIDTH	±0.051 [±0.002] HEIGHT	WIRE
INSUL BARREL CRIMP			WIRE BARREL CRIMP			

△ 2	H03 PHOS BRONZE	3.05-4.32 DIA [0.120-0.170]	18-14 AWG	1217160-1
FINISH	MATERIAL	INSULATION RANGE	WIRE RANGE	PART NO
DO NOT SCALE PRINT. UNLESS SPECIFIED DIMENSIONS IN mm [INCHES] TOLERANCES ON: 2 PLC DEC ± 0.25 [0.010] 3 PLC DEC ± - ANGLES ± -	DR 24MAR1999 PHILLIP M FORTNEY CHK 24MAR1999 JEFF R RUTH APPD 24MAR1999 JEREMY DUNCAN APPD 24MAR1999 DAVE BRATINA	AMP AMP Incorporated Harrisburg, PA 17105-3608		
MATERIAL SEE TABLE	PRODUCT SPEC -	NAME RING		
FINISH SEE TABLE	APPLICATION SPEC -	SIZE B	CAGE CODE 00779	DRAWING NO 1217160
	WEIGHT -	SCALE 5:1	SHEET 1 OF 1	RESTRICTED TO -